

Technical requirements

1. Parts must not have burr and injection molding defects which affect usability
2. The surface is bright and clean, smooth, no waterlogging, etc
3. The " " is the important feature, "! "is the key features
4. Unmarked tolerance dimensions carry out according to the GB - T14486-2008 - MT6 level
5. if assembly holder required for production plan
6. Coordinate good with clip, is not easy to fall out when the card is first gear clamp, the second tranche can lock the card terminal

②	LOCK	PA66+GF	1	RED
①	HOUSING	PA66	1	BLACK
	NAME	MATERIAL	Q' TY	COLOUR

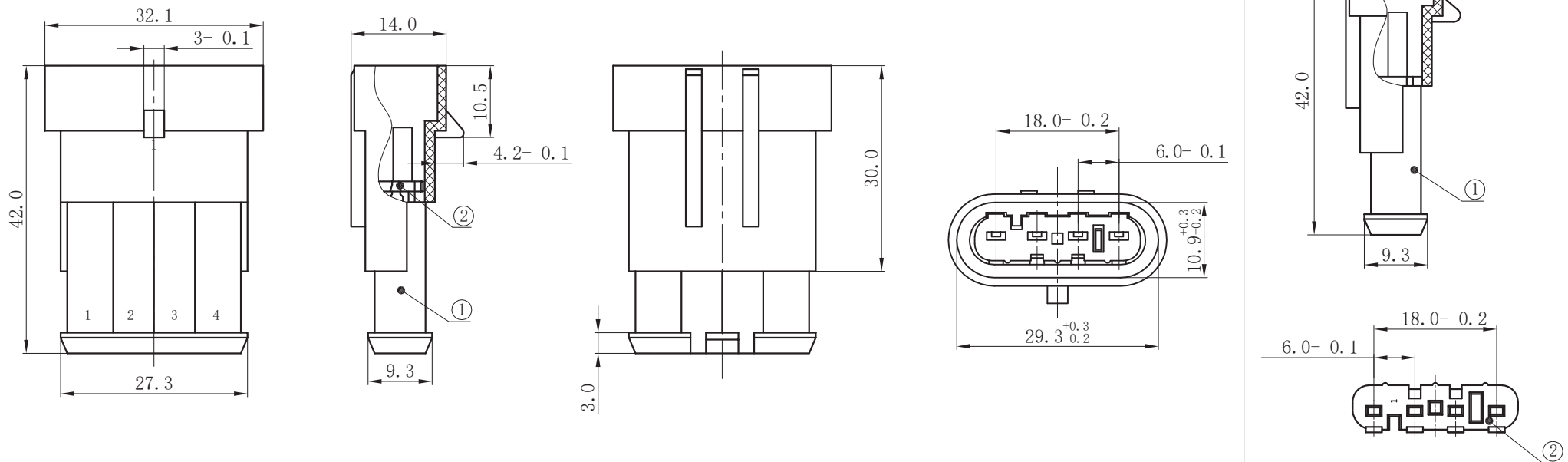

euro-conn



UNITS: mm

SHEET SIZE: ISO A4

SCALE:

> 0 ~ 3

> 3 ~ 18

> 18 ~ 50

> 50 ~ 120

± 0.12

± 0.15

± 0.3

± 0.5

! I prodotti e le caratteristiche possono cambiare senza preavviso.
The products and their features may change without notice.

CBDJ7041-1.5-11