

The technical requirements:

1 pieces of the surface are not allowed to have obvious scratches, cracks, deformation

Stamping defects, chamfer is clear, stamping Feng is less than 0.02mm

2 not note round R R0.2 to R0.5mm

3 product beading and stiffener depth 0.08-0.1mm

4 "+" is the important characteristic, "As the key characteristics.

5 did not note the size tolerance in table GB/T15055-2007-m.

①	1.0-1.5	3.4	5.2	3.0	4.7
	WIRE RANGE (mm ²)	W1	W2	H1	H2

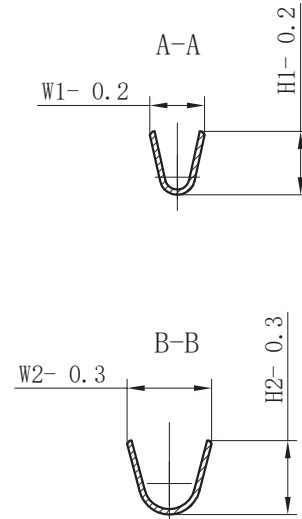
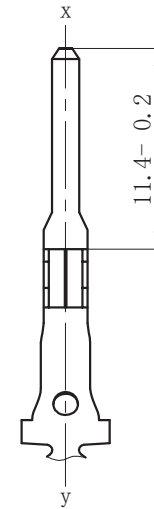
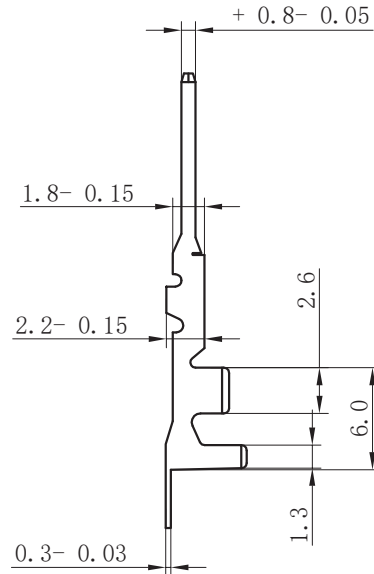
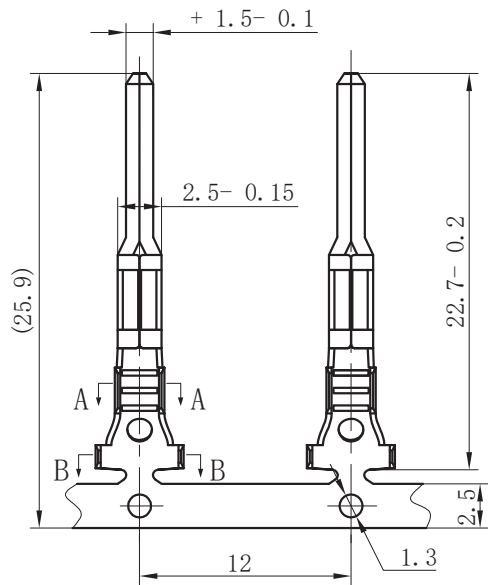

euro-conn



UNITS: mm

SHEET SIZE: ISO A4

SCALE: 10:1

> 0 ~ 3

> 3 ~ 18

> 18 ~ 50

> 50 ~ 120

± 0.12

± 0.15

± 0.3

± 0.5

! I prodotti e le caratteristiche possono cambiare senza preavviso.
The products and their features may change without notice.

CBFJ611-1.5